

## Sitting Box Assembly Instructions

Thank you for purchasing an Align-Pilates Sitting box.

- A. Contents
- B. Assembly Instructions
- C. Safety
- D. Care & Maintenance
- E. Warranty

### A. Contents

Your sitting box consists of:

1. Padded and upholstered top board
2. 2 x side frames and 1 x base frame
3. 4 x M6 40mm long allen bolts
4. 8 x M6 15mm short allen bolts and washers
5. Allen key

### B. Assembly Instructions

1. Bolt the 2 side frames to the base frame using the 8 short allen bolts & washers. First insert each of the 8 bolts hand tight and then tighten one after the other using the allen key supplied. See Fig. 2
2. Turn the padded top upside down and place on the floor.
3. Bolt the metal frame to the padded top using the 4 long bolts and washers. First insert all 4 bolts hand tight and then tighten one after the other using the allen key supplied, until all are tight.

Congratulations your Sitting box is ready for use!

### C. Safety

Please note this sitting box is designed to be used on a reformer carriage. The metal frame therefore does not have any slip feet, as these would damage the carriage upholstery. When in use on a reformer the sitting box is prevented from slipping backwards by placing against the shoulder rests. If you wish to use your sitting box on the floor, please always use on a suitable mat to prevent the box from slipping.

### D. Care & Maintenance

Always ensure that belts, jewellery and shoes are removed when working on the Sitting box as buckles, rings, watches and bangles can all end up damaging the upholstery.

For care of upholstery we recommend using *GymWipes Advantage Sanitising wipes* which are alcohol free, will not damage your upholstery & are available worldwide

Please regularly check all the bolts are securely fastened and if necessary retighten.



Fig.1

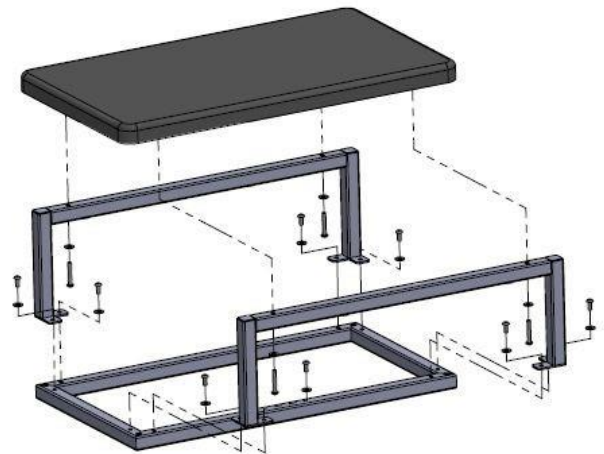

Fig.2

## **E. ALIGN-PILATES™ LIMITED LIFETIME WARRANTY Terms of Limited Lifetime Warranty**

Align-Pilates offers the following limited lifetime warranty, for the periods as stated below from the date of purchase, to the original owner of their products, upon presentation of an original invoice in their name. The warranty is a Light Commercial Warranty allowing for a maximum usage of 27.5 hours per week.

Align-Pilates will repair or replace any mechanical part that malfunctions due to defects in materials and/or workmanship during the warranty period. The warranty excludes normal wear and tear, damage due to negligence or misuse, abuse, modification or unauthorized repair; scratches to the finish, and tears or indents in the upholstery. Align-Pilates will, at its discretion, repair or replace any parts deemed defective during the warranty period. If we opt to repair or replace your apparatus, this may require that your product is returned for inspection at our premises prior to sending out replacement apparatus. Parts repaired or replaced under the terms of this warranty will be warranted for the remainder of the original warranty period only. This warranty does not cover shipping charges, customs clearance fees (where applicable) or any costs incurred in installing repaired or replacement parts shipped under the provisions of this warranty.

This warranty will be null & void if springs are not changed as specified or, if all safety, maintenance and usage instructions as specified in the manuals are not observed or, if the equipment is used for any other purpose other than for Pilates repertoire or if the equipment has been subjected to accident, abuse, improper service, or modification not authorised by the Align-Pilates.

### **Duration of Limited Warranty**

#### **1) Metal Frames & welded components.**

10 year warranty

#### **2) Upholstery**

The upholstery fabric on Align-Pilates equipment will be replaced if it fails to give normal wear for 90 days from the date of delivery. Proof of damage may be required. This warranty does not cover cuts, scratches, burns, stains, soiling, or damages caused by unreasonable use such as wearing jewellery or inappropriate clothing whilst using the equipment. Align-Pilates reserves the right to substitute an equivalent fabric if an identical fabric is not available. Upholstery must be properly cared for laid out in the manual.

### **Warranty Return Procedure**

The customer must call Align-Pilates or its authorized Distributor for authorization prior to returning the equipment. The customer is responsible for the cost of returning products to Align-Pilates (or their appointed Distributor) for warranty adjustment should this be deemed necessary. The customer is responsible for any damage or loss during shipment back to Align-Pilates (or their appointed Distributor). The customer is responsible for the cost of return freight to them in the event Align-Pilates decline to make a warranty adjustment. Align-Pilates do not accept responsibility for any items returned without a pre-approved authorization number, which must be clearly marked on the outside of the package.

### **Limitation of Liability**

The above is our exclusive warranty and is in lieu of all other warranties, express or implied, including warranties of merchantability or fitness for any purpose. In no event shall Align-Pilates or their Distributors be liable for incidental, consequential or punitive damages.

### **CONTACT**

Align-Pilates Equipment Ltd, 430 Enterprise Way, Vale Park, Evesham, Worcs WR11 1 AD, UK. Tel: + 44 1386 425920. [customercare@align-pilates.com](mailto:customercare@align-pilates.com)

**[www.align-pilates.com](http://www.align-pilates.com)**