

# Align-Pilates®



## **F2 Folding Reformer** Assembly Instructions & User Manual

# Introduction

The F2 reformer was developed to bring the benefits of a Pilates Reformer workout in to your home, without the need to have a space dedicated to your Pilates workout. Featuring the same springs as our professional reformers, the F2 offers smooth progressive resistance and a range of adjustments to fine tune the machine for your workout. The F2 folds up in a matter of minutes into a compact and self-contained machine that can be easily wheeled around and stored safely out of the way.

## Specification & Adjustability

- Travel: 95cm
- Resistance: 4 Nickel plated music wire springs (2 Medium, 1 Strong and 1 Light)
- x4 Foot Bar positions: 3 plus down & stowage position
- Removable rope risers with 3 height options & 4 easy rope length adjustments
- New Align-Pilates double loop handles with "silent" metal free connectors for a quieter workout
- 3 position head rest, with locking string for stowage
- Steel frame with 8 wheel design. Removable & lockable shoulder rests. Locking bolts to lock reformer both open and closed. 4 Wheels to enable movement of the reformer when open or closed. 6 adjustable feet to ensure your reformer sits flat and can run smoothly
- ISO20957-1 Class H Item. Max User Weight: 120Kg. Suitable for users: 145cm – 193cm (4'10 – 6'4")

## Dimensions:

- Open Size (maximums): 247cm x 70cm x 47cm
- Carriage size: 89cm x 58cm (w)
- Folded size (maximums) 143.5cm x 70cm x 34.5cm
- Weight: 55Kg

## Packaging & Delivery:

Delivered in 2 boxes with total GW of 66.6Kg being:

- Box 1: Frame 133.5 x 69.5 x 32.5cm GW 46Kg
- Box 2: Carriage 102.5 x 62.5 x 17cm GW 20.6Kg

## BEFORE YOU START

You may find it beneficial to see a video on how to open & close your F2 reformer before you start. Please scan the QR code below to take you to the video or search YouTube for "Fold F2 Reformer".

How to set up your F2 Reformer:



How to fold up your F2 Reformer:



## F2 Reformer Map:

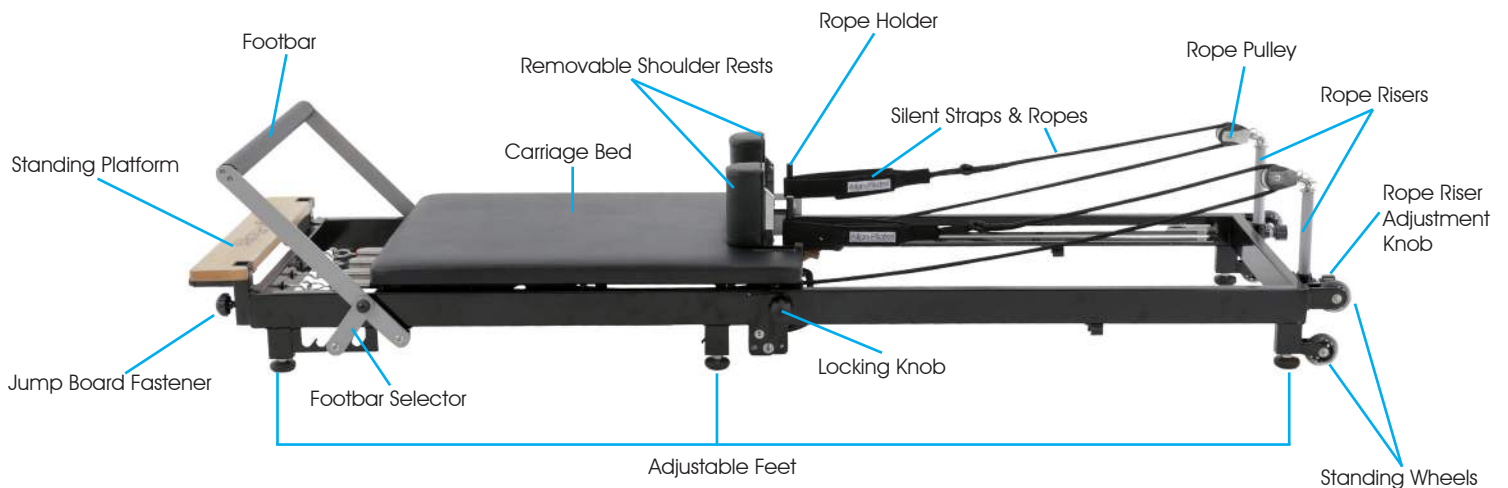

# Assembly

## 1. Unpacking the F2 reformer

Allowing for space to assemble the reformer, carefully open both boxes and remove the polystyrene blocks and other packaging material. The smaller of the two boxes contains the carriage bed and a plastic bag containing smaller parts, open and lay out the parts (leave the carriage bed in the box for now). The two locking knobs should already be inserted in the frame of the F2 reformer, see Fig.1 & 2. *Please note: the rope risers with pulleys are already clipped to the rope riser holders on the frame.*



**Fig.1** Locking Knob



**Fig.2**

## 2. Unfolding your F2 reformer & adjusting the foot bar

Please watch the video before unfolding for the first time. You can see the video QR code on page 2 of this manual.

**Warning: We recommend the F2 reformer is opened and closed by two people to minimise the chance of injury. However the F2 can be opened and closed by a single person with relative ease, as the lifting weight is similar to lifting a heavy suitcase. If planning to open and close the F2 on your own we suggest familiarising yourself with the process using 2 people first and always be sure to use correct lifting technique. If you have back or similar issues you should avoid opening the F2 alone.**

With assistance, lift the F2's frame out of the box and stand it on its feet. Carefully cut the two cable ties that secure the aluminium foot bar and the silver footbar selector bar from the frame, see Fig.3. Before unfolding the F2, remove the rope risers with pulleys from the holders and place to one side, location shown in Fig.4.

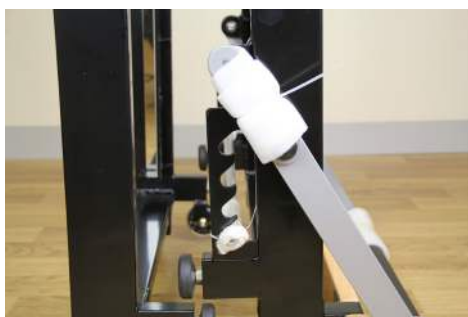

**Fig.3**



**Fig.4**

**Note: upon opening the F2, the standing platform will remain approximately where it is whilst the wheels move away, first ensure there is space for the reformer to open in this manner.** Carefully unscrew the two locking knobs, whilst using your foot to prevent the reformer opening. Then with your hands towards the centre of the lowering/lifting handle and your palm facing towards the carriage (to avoid wrist injury) slowly lower the frame to the floor. Be sure to keep your hands and clothing clear of the hinge points and be careful not to lower the centre leg on to your foot. Once flat on the floor replace the locking knobs. **The reformer must always be locked open before use.**

To attach the footbar selector bar to the footbar adjustment arm, insert the bar through the reformer resting on the selector gear teeth. Then, using the two bolts with washers and allen key provided, screw these into the bar on either side through the hole in the footbar adjustment arm and then fully tighten the bolts see Fig.5.



**Fig.5**

### 3. Levelling the frame

**The F2 has 6 adjustable feet to ensure the reformer is level or, it will not run smoothly.** The feet are adjusted by screwing them in or out to adjust the height. Using a spirit level, adjust the feet to level the frame, ensuring that each foot is firmly in contact with the floor. *Tip: Always lower a high foot before raising a low foot.*

### 4. Assembly of the carriage bed & attaching the ropes

Remove the carriage bed from its box and lay it face down on a soft and dry surface, such as clean carpet, to avoid damaging the leatherette upholstery. Remove the elastic retaining strap and attach the x4 springs. Now pass the elastic retaining strap through the eye of each of the springs and reattach the hooks to secure the springs, see Fig. 6.

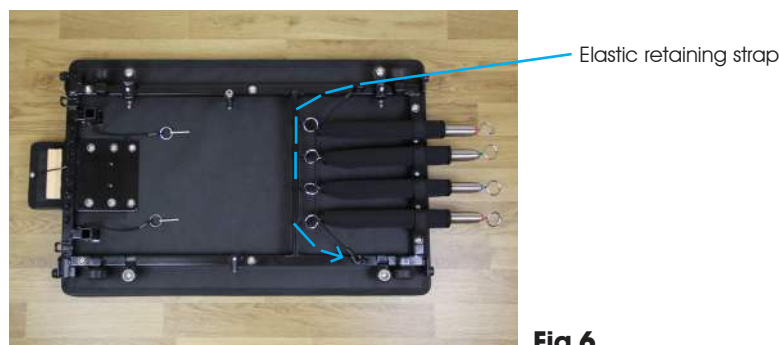
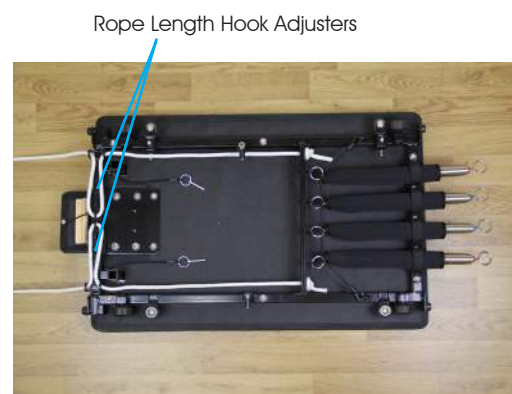

**Fig.6**

Locate the pair of rope risers with rope pulleys and the pair of ropes (**Note: each rope has an eyelet on one end**). Thread the unfinished end of each rope through one of the rope pulleys (see Fig.7) and lay out each rope riser with rope threaded through the pulley, at the headboard end of the bed. Thread the ropes into the carriage bed, *Fig.8 shows white ropes for illustrative purposes only*. Once each rope has been threaded, tie a simple “over-hand” knot on the end of each rope, then ensure the tails are the same length - once they are pull the knots tight. You may need to fine tune the final knot position to ensure the ropes are the same lengths. Use the series of hooks to quickly adjust the length of each rope, as shown in Fig.8. For more details see point 10 on page 7.



**Fig.7**



**Fig.8**



## 5. Placing the bed in the frame and final assembly

Lower the foot bar to the position closest to the foot board. On the underside of the reformer bed note the position of the fixed hook - see Fig.9. This hook runs beneath the wheel runner when in use and is there to prevent the carriage from tipping - care must be taken to hook it under the runner as the bed is installed into the frame. With assistance, lift up the carriage bed and flip it over, ensuring the springs are pointing towards the foot bar. Now carefully lower the carriage bed into the frame, taking care not to hit the frame, gently angle the bed so that the hook passes beneath the runner of the frame. Once the carriage bed is in position, gently slide the bed to the foot of the reformer and attach one of the springs. On the opposite runner to the hook is a second rotating hook. Rotate this to hold the bed in place so the carriage cannot fall out when stood up. To remove the carriage in future the rotating hook must be turned first and then the bed lifted out at an angle, lifting the rotating hook side of the reformer first.

Fig.9



Fixed Hook

Adjustable Hook

## 6. Attaching & adjusting the rope risers

Partially unscrew the rope riser fastener on the end of the frame and insert the rope riser. Pull back on the fastener and slide the rope riser to the desired height. When happy with the height, let go of the fastener and twist to tighten, securing it in place. Be sure that the locking pin is engaged in one of the holes of the rope riser to secure it safely in position Fig.10 & 11.



Fig.10



Fig.11

The F2 allows you to set your ropes at 4 different heights. To adjust the rope height simply loosen the fastener then pull out to release the pin. You can then move the rope riser up or down into one of the 4 holes. Fig.12.

## 7. Attach the Double Loop handles

Thread the nylon loop of the handle through the rope eyelet and then thread the loop handle through the nylon eyelet to secure the handle to the rope as per Figs.13, 14 & 15. Pull tight to check it is secure.



Fig.12



Fig.13



Fig.14



Fig.15

## 10. Installing & locking the shoulder rests

Finally install the shoulder rest by sliding the chrome bar in to the receiver - see Fig.16. Once inserted the shoulder rests lock in to place with a pin that is attached to the underside of the carriage which inserts through the hole in the bottom of the chrome bar. *Note: If the shoulder rests are not locked the locking pins will knock against the lifting / lowering bar when in use, so always be sure to lock the shoulder rests.*



Fig.16



Fig.17

## 8. Working with springs

The F2 is fitted with 4 springs, in 3 strengths to offer a wide range of possible resistances. Green = Strong x 1, Red = Medium x 2, Blue = Light x 1, see Fig.17. The springs can be used in any combination, although when using the reformer for asymmetric exercises, please ensure the springs selected are on the same side that you are working on, or set equally in the middle, to ensure the carriage runs true. E.g. when doing a hip flexor stretch with one foot on the floor and the other on the shoulder rest. **Warning: After unfolding your reformer and before use always check that the springs are properly attached to the underside of the carriage by pulling them firmly - the spring should stretch but not move or the spring may have become unhooked.**

## 9. Folding the F2 reformer

**Watch the video before doing for the first time (see point 10).** Attach at least one spring to the carriage,

ensure both anti-tipping carriage hooks are engaged. This will hold the carriage to the frame when the reformer is folded. Remove the rope risers and attach them into the clips on the underside of the frame and lay the ropes on the floor in the centre of the frame, see Fig.18.

Remove the shoulder rests and set to one side, then remove the locking knobs and with assistance, with one person on either side of the reformer, place hands in the indicated position on the lowering/lifting handle as per Fig.19. Carefully lift the reformer until it is fully upright,

ensure the footbar adjuster arm bar sits in the second from the bottom footbar position so the footbar helps to stabilise the F2 then, whilst preventing the reformer from reopening with your foot, replace the locking knobs. **Note: the F2 must always be locked when in the closed position to prevent accidental opening.** The shoulder rests can now be stored as per Fig. 20 and the ropes hung from the shoulder rests. The head rest can then be secured using the locking string. It is now safe to wheel the reformer away for storage - simply tip on to the wheels and move like a wheel barrow.



Fig.18



Fig.19



Fig.20

**PALMS MUST FACE TOWARDS THE CARRIAGE**  
- Illustration shows 2 person lift

## 10. Adjusting the rope length

Once your ropes are set up as outlined in point 4, fine tuning the rope length is easy. Simply move the rope along the hooks. When the rope is not on any hooks it is at its longest (Fig. 21 B) and when the rope is over the centre hook it is at its shortest (Fig. 21 A). There are 5 available rope lengths adjustment positions.



Fig.21

## 11. Periodic Maintenance

Please check the apparatus before first use and after each of the first few uses to check that all the fittings are securely fastened. Thereafter, it is important to make regular maintenance checks. Equally inspection should be made immediately if any part appears not be operating correctly or something appears to be loose. Below follows a basic maintenance guide though our detailed maintenance guide and a sample maintenance log can be downloaded from <https://www.mad-hq.com/align-pilates-resources>

- **Springs** - inspect all springs for signs of wear, look for deformation, kinks, gaps and corrosion. Springs showing signs of damage must not be used and must be replaced immediately. Springs must be replaced every 2 years or after 3,000 hours, whichever is first.
- **Foot Bar** - check that all allen bolts securing the bar to the aluminium arms and to the steel engagement bar and through the frame are tight and that the Foot bar Twist/Pull locking pin is working properly. Note if the red button sticks out on its own this is a warning sign to show the locking pin is not properly engaged.
- **Runners** - ensure the runners are clean and free from grit to enable the smooth running of the reformer. If excess dirt is spotted on the runners then the wheels may also need cleaning. We recommend cleaning the runners with a window cleaner eg. Windowlens.
- **Ropes and Handles** - check ropes for signs of wear, fraying or nicks and replace if damaged. Check stitching on handles is intact and handles are not overly worn. Check the handle clips are working.
- **PVC Upholstery** - regularly clean all upholstery on your equipment, we recommend using Gym Wipes from Vital Clean ([www.vital-clean.de](http://www.vital-clean.de)) as these will not damage your upholstery. Beware that some bactericides and strong or abrasive cleaning products will dry out the vinyl and reduce its life. Vinyl is non-absorbent, so will not absorb dirt so surface wiping is only required.
- **Wheels** - Remove the carriage and check for smooth rotation and signs of damage. If the wheels are not turning smoothly or the wheels are damaged this will impede smooth running and the wheels need to be replaced.
- **Shoulder Rests** - check the pads are securely bolted on to the metal frame - if loose retighten.  
**Spring hooks** - hand check that all eye hooks will not move. If loose remove, apply loctite and retighten.
- **Nuts & Allen Bolts** - check all nuts and bolts are tight, including those on the rope pulley wheels and those securing the head rest.
- **The Main Hinge & Lifting Bar** - check that hinge bolts are tight, but avoid overtightening the allen bolt in the cross support or the hinge will become stiff.

Congratulations! You are now ready to use your F2 Reformer. Now would be a good time to make a note to replace your springs in 2 years or, within 3,000 hours of use, whichever is sooner. We hope that you enjoy using your new F2 reformer!

### Troubleshooting Smooth Running of your F2 Reformer

If your reformer is not running smoothly please follow these step in order to get it back up and running smoothly:

1. Check the reformer is level using a spirit level and adjust the feet as described
2. Check the runners and wheels are clean and free from dirt and grit



3. Check the wheel Alignment of the side wheels
  - a) Occasionally the side wheels on your reformer may be knocked out of alignment. You will know this if you hear squeaking where the side of one of the horizontal wheels hits the side of the runner. If this is the case adjustment is easy by following these simple steps
  - b) Identify which side of the carriage the fixed wheels are on (this should be the right hand side if looking from the spring bar end towards the head rest).
  - c) Disconnect all springs and roll the carriage to the riser end of the reformer. Now push the carriage from the side ensuring both the fixed side wheels are touching the side wall of the runner.
  - d) Now tilt the reformer on its right hand side and using an 8mm spanner slacken the locking nuts (Fig 22) on each of the adjustable side wheels, then screw in or out allen Bolt 2 (Fig 22) so the adjustable side wheel stops approximately 2mm from the edge of the runner. Holding the allen bolt in position with an allen key retighten the locking nut 2. Then tighten the allen bolt 1 and as before tighten the locking nut. Repeat the process for the other side wheel.
  - e) Lower the reformer, ensuring it is level and then with NO springs attached gently move the carriage for the full length of the frame and back, ensuring you push it from a central position so as to keep it in line, now attach a pair of springs and check the bed is running smoothly with no squeaking, additional fine tuning may be necessary to achieve optimal performance.
4. Check the wheels and bearings are not damaged. If damaged replace.

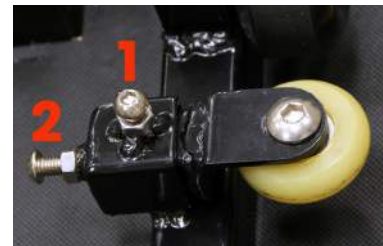

**Fig.22**

## 16. Basic Reformer & Exercise Safety

If you are not familiar with using a Pilates reformer we suggest you seek advice from a qualified Pilates professional in order to learn how to get the most out of your reformer and to cover the basic safety aspects of using this type of equipment. A number of companies also offer short safety induction courses.

- a) Pilates is about smooth and controlled movement, when performing exercises try to prevent the carriage from slamming in to the carriage stops and the springs from recoiling in an uncontrolled manner as this can damage the spring and shorten its life.
- b) Secure the carriage with at least one spring when your Reformer is not in use, Do not get on the carriage when there are no springs attached unless you deliberately want to do this.
- c) When standing on the reformer always put your first foot on the standing platform and then the other on the carriage. When getting off the reformer from standing take your foot off the carriage first and then step down off the standing platform
- d) Use your reformer in a clear space with at least 1m of space all around the machine. This equipment is for indoor use only on a firm and flat surface
- e) When using a reformer less is often more, remember when performing certain exercises less spring resistance makes the exercise more challenging.
- f) Before starting any exercise program, consult a physician.
- g) Before using the equipment, read and follow instructions in the safety manual and obtain thorough instruction from a Qualified Trainer.
- h) Use equipment only for recognised Pilates repertoire.
- i) Stop exercising if you experience chest pain, feel faint, have difficulty breathing or experience musculoskeletal discomfort.
- j) Keep clothing, body and hair free from all moving parts.
- k) Do not use if equipment appears worn, broken or damaged. Do not attempt to repair equipment yourself. Ensure equipment that is out of service cannot be used.
- l) Do not allow children to use or be around equipment without adult supervision.
- m) If folding the equipment for storage be sure it is kept in a safe place, on level ground and away from children or activities that could knock it over. If in doubt secure the equipment in an appropriate manner.
- n) Do not exceed the maximum user weight for the equipment which is 120Kg.
- o) The F2 can be moved around either open or folded by a single person with relative ease, as the lifting weight is similar to lifting a heavy suitcase. However, if you have back or any similar issues you should avoid moving or folding the F2 alone.



### 17. Accessories for your F2 reformer

If you have not already purchased them the following accessories may be of interest to enhance your F2 Reformer:



F2 Jump Board



Sitting Box & Foot Strap



Neck Pillow

## Complete your Studio

Align-Pilates offers a full range of commercial quality Pilates apparatus, at the most competitive prices in UK & Europe. To see the complete range of Align-Pilates apparatus & a complete range of Pilates Studio equipment & mat work accessories please visit [www.Align-Pilates.com](http://www.Align-Pilates.com)



**Exploded diagrams:**

Note: For larger images of the exploded diagrams and a detailed parts list please download from: <https://www.mad-hq.com/align-pilates-resources>

**F2 REFORMER CARRIAGE**

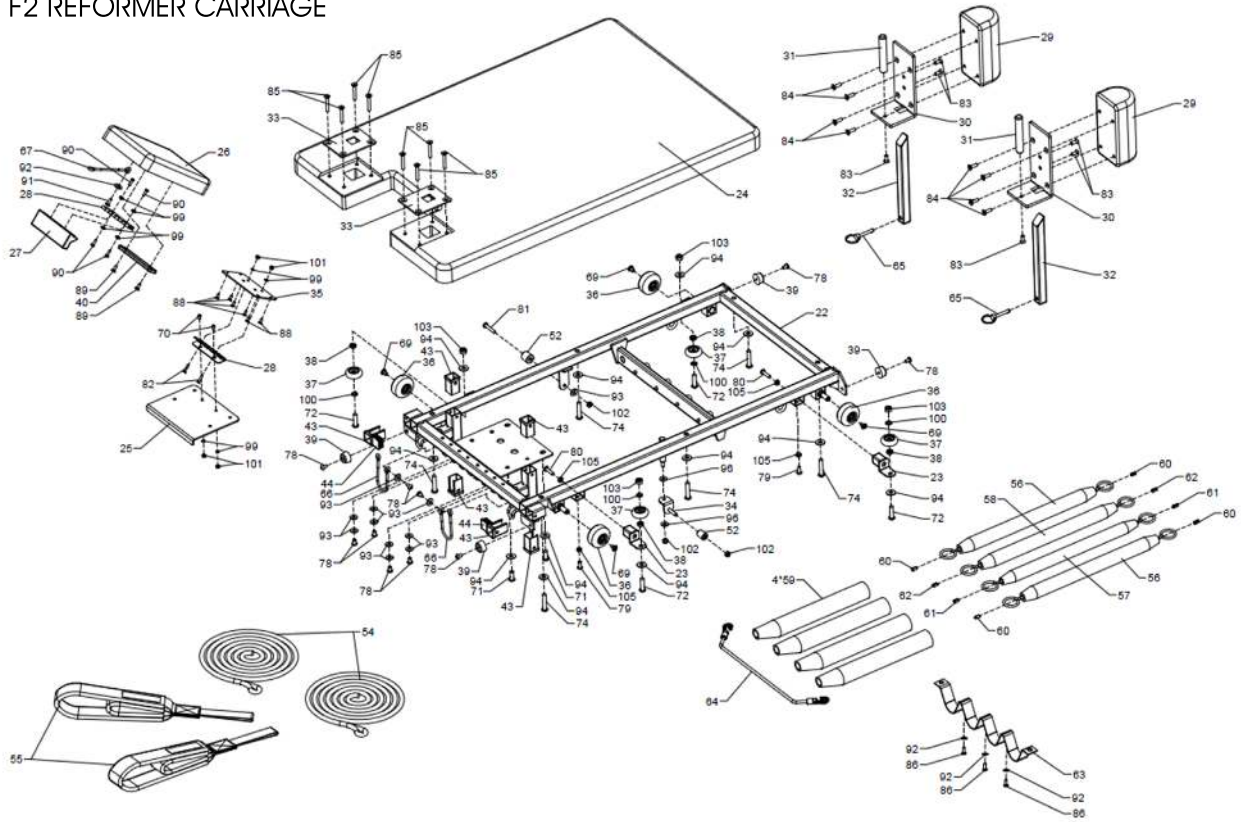

Align-Pilates

Copyright Align-Pilates Equipment Ltd

**F2 REFORMER FRAME**

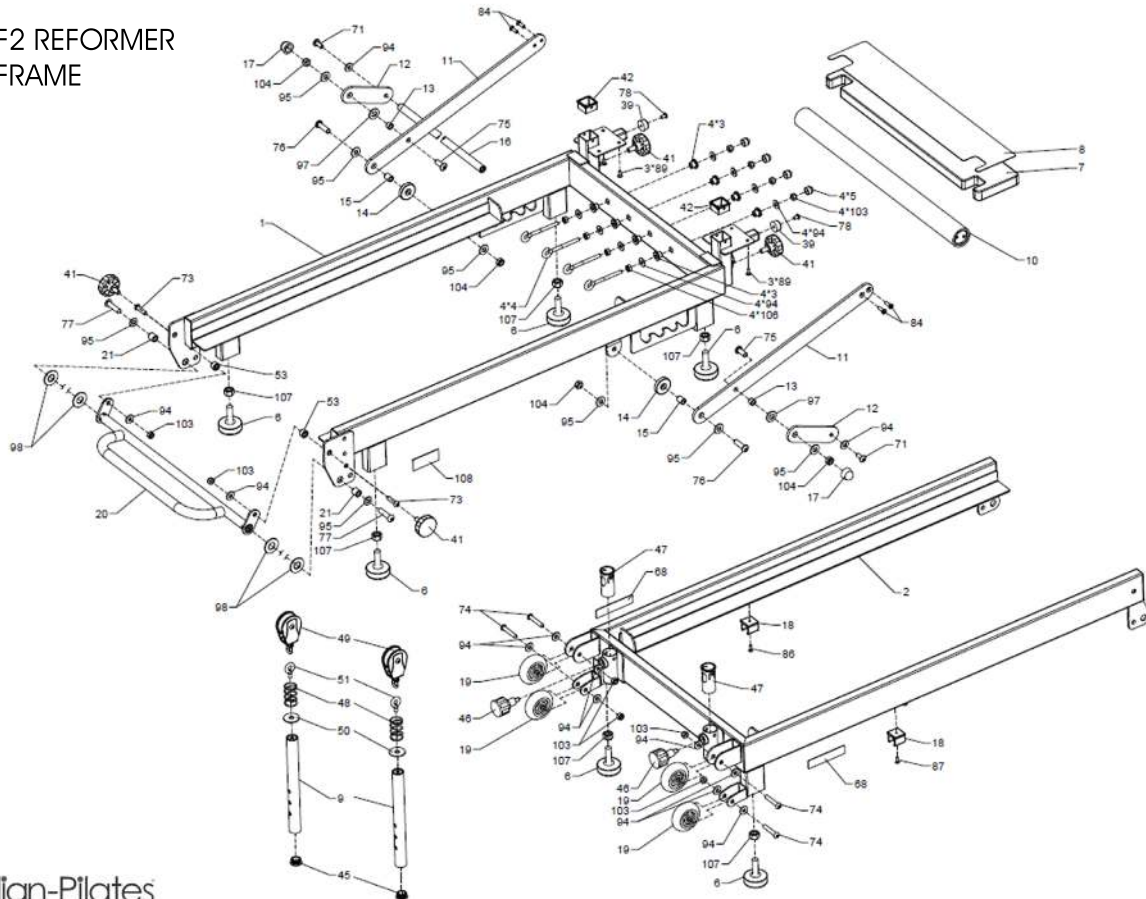

Align-Pilates

Copyright Align-Pilates Equipment Ltd

# Warranty Information

## **ALIGN-PILATES™ LIMITED LIFETIME WARRANTY**

### **Terms of Limited Lifetime Warranty**

Align-Pilates offers the following limited lifetime warranty, for the periods as stated below from the date of purchase, to the original owner of their products, upon presentation of an original invoice in their name. The warranty covers domestic usage only - the F2 is not warranted for commercial or professional use. Align-Pilates will repair or replace any mechanical part that malfunctions due to defects in materials and/or workmanship during the warranty period. The warranty excludes normal wear and tear, damage due to negligence or misuse, abuse, modification or unauthorized repair; scratches to the finish, and tears or indents in the upholstery. Align-Pilates will, at its discretion, repair or replace any parts deemed defective during the warranty period. If we opt to repair or replace your apparatus, this may require that your product is returned for inspection at our premises prior to sending out replacement apparatus. Parts repaired or replaced under the terms of this warranty will be warranted for the remainder of the original warranty period only. This warranty does not cover shipping charges, customs clearance fees (where applicable) or any costs incurred in installing repaired or replacement parts shipped under the provisions of this warranty.

This warranty will be null & void if springs are not changed as specified or, if all safety, maintenance and usage instructions as specified in the manuals are not observed or, if the equipment is used for any other purpose other than for Pilates repertoire or if the equipment has been subjected to accident, abuse, improper service, or modification not authorised by Align-Pilates.

### **Duration of Limited Warranty**

1) The F2 reformer carries a 2 year warranty for the main steel frame and standing platform and the following warranty on other parts

a) Springs

2 year / 3,000 hours warranty is given on all springs, excepting that a decrease of 5% of the spring power per 1,500 hours usage is acceptable according to international standards. Align-Pilates Springs should be replaced after a maximum of 3,000 hours use or 2 years, whichever is earlier. In the event of any signs of damage or wear springs should be replaced immediately regardless of age or usage.

b) All other parts including wear and tear parts including wheels, straps, ropes: 1 year

c) Upholstery

The upholstery fabric on Align-Pilates equipment will be replaced if it fails to give normal wear for 90 days from the date of delivery. Proof of damage may be required. This warranty does not cover cuts, scratches, burns, stains, soiling, or damages caused by unreasonable use such as wearing jewellery or inappropriate clothing whilst using the equipment. Align-Pilates reserves the right to substitute an equivalent fabric if an identical fabric is not available. Upholstery must be properly cared for as laid out in the manual.

### **Warranty Return Procedure**

The customer must call Align-Pilates or its authorized Distributor for authorization prior to returning the equipment. The customer is responsible for the cost of returning products to Align-Pilates (or their appointed Distributor) for warranty adjustment should this be deemed necessary. The customer is responsible for any damage or loss during shipment back to Align-Pilates (or their appointed Distributor). The customer is responsible for the cost of return freight to them in the event Align-Pilates decline to make a warranty adjustment. Align-Pilates do not accept responsibility for any items returned without a pre-approved authorization number, which must be clearly marked on the outside of the package.

### **Limitation of Liability**

The above is our exclusive warranty and is in lieu of all other warranties, express or implied, including warranties of merchantability or fitness for any purpose. In no event shall Align-Pilates or their Distributors be liable for incidental, consequential or punitive damages.

### **Further Information**

This warranty is issued by Align-Pilates Equipment Ltd. Contact details: 430 Enterprise Way, Vale Park, Evesham, Worcs WR11 1 AD, UK. Telephone + 44 1386 425920. Email: [customercare@align-pilates.com](mailto:customercare@align-pilates.com)

For more information about Align-Pilates equipment please visit: [www.align-pilates.com](http://www.align-pilates.com)

For larger images of the exploded diagrams and a detailed parts list please download from:

